

SANY[®]

SPECIFICATION



 200t

 85.5m

 6272kN·m

SAC2000S8

SANY ALL TERRAIN CRANE

QUALITY CHANGES THE WORLD

crane.sanyglobal.com

V1.0

It is one of the core business units in SANY Group, specializing in the development and manufacturing of high-end wheel cranes, crawler cranes and tower cranes, including the complete range of wheel cranes from 8 to 1800t, crawler cranes from 25 to 4500t and tower cranes from 6 to 185t.



SANY CRANE



8-section oval boom, with full extension of 85.5 m; jib, with standard extension of 18 m (optional total 34 m with additional two 8 m sections), realizing greater lifting height, radius and capacity.

Counterweight can be moved rearward by 500 mm, which makes it possible that 60t counterweight delivers same performance as 68t counterweight. 18t counterweight can be loaded with the crane when traveling.

Excellent power chain: BENZ OM460LA.E3A/1 engine + German ZF automatic transmission with hydraulic retarder + German Kessler axles with disc brake.

5-axle all-terrain carrier, H-type outriggers, hydro-pneumatic suspension, all-wheel steering, 4-axle drive, 6 steering modes, minimum steering radius of 9.7m.

Low-noise and energy-saving concept is implemented with mechanical single engine, free of risk of upgrades on vehicle emissions, resulting in 35% decrease in maintenance costs.

Independent hydraulic systems for crane and chassis (independent variable piston pump + slewing pump + auxiliary pump + fluid tank hydraulic system for crane), energy saving of 15%-20% than hydraulic single-engine mechanism.

Cable wiring for superstructure, with high reliability.



85.5m

Full-extension boom

500mm

Counterweight adjustment

9.5×8.3m

Outrigger span



Overall Dimensions

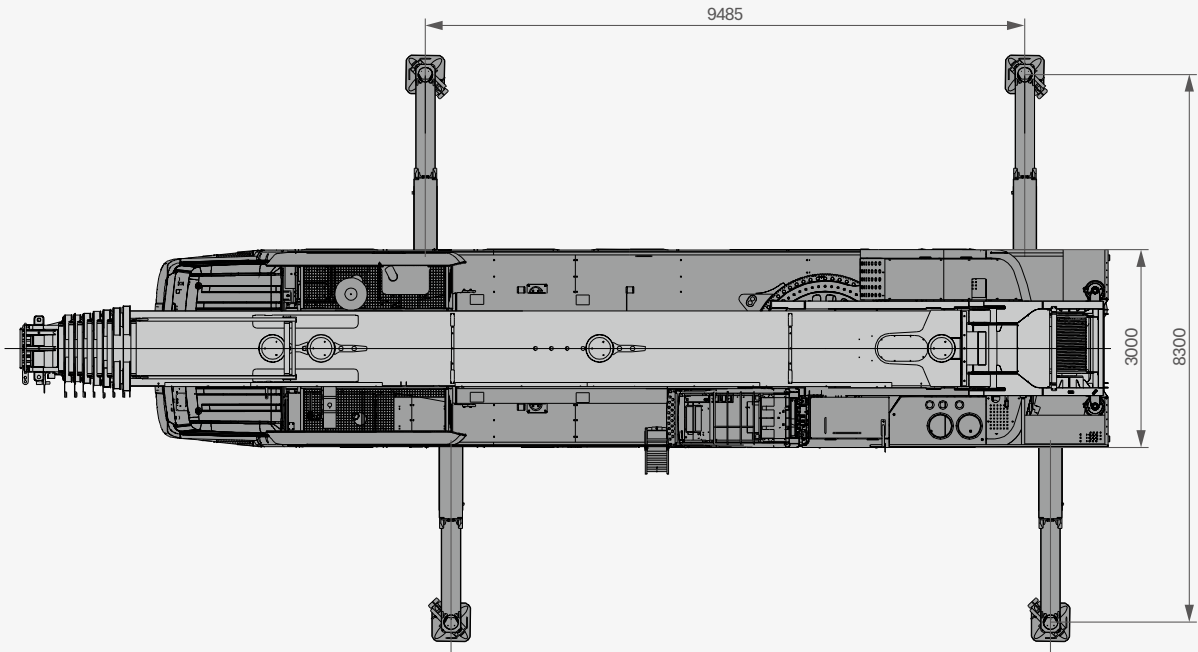
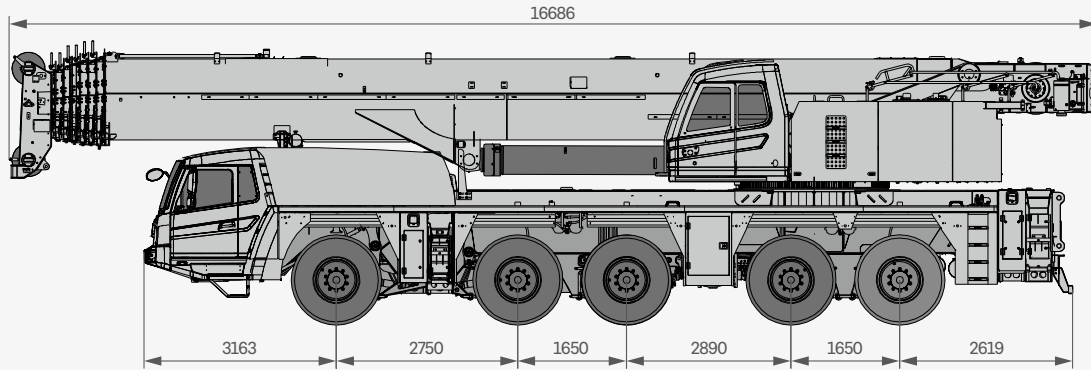

Technical Specification

CATEGORY	ITEM	UNIT	VALUE	
CAPACITY	Max. lifting capacity	t	200	
WEIGHT	Gross weight	kg	66000	
POWER	Engine model	-	BENZ OM460LA (EU Stage III A)	
	Max. engine power	kW/rpm	360/1800	
	Max. engine torque	N·m/rpm	2200/1300	
DIMENSIONS	Overall length	mm	16686	
	Overall width	mm	3000	
	Overall height	mm	4000	
TRAVEL	Max. travel speed	km/h	80	
	Min. steering radius	m	9.7	
	Wheel formula	-	10 × 8 × 10	
	Min. ground clearance	mm	271	
	Approach angle	°	16	
	Departure angle	°	12	
	Max. gradeability	-	45%	
	Fuel consumption per 100km	L	70	
MAIN PERFORMANCE	Working temperature range	°C	- 20~+40	
	Min. rated lifting radius	m	3	
	Tail slewing radius	m	4.33 (4.83 with counterweight mounted)	
	Boom sections (Qty.)	-	8	
	Boom shape	-	U shape	
	Max. lifting moment	Basic boom	kN·m	6272
		Full-extension boom	kN·m	2074
	Boom length	Basic boom	m	14.4
		Full-extension boom	m	85.5
		Max. combination of boom + jib	m	96.4 (standard), 112.4 (optional)
	Max. lifting height	Basic boom	m	14.7
		Full-extension boom	m	85
		Max. combination of boom + jib	m	112
	Outrigger span (Longitudinal × Transverse)	m	9.5 × 8.3	
	Jib offset	°	0, 15, 30	
AIRCONDITIONER	In operator's cab	-	Heating & cooling	
	In driver's cab	-	Heating & cooling	

Technical Specification



Axle Load

Axle	1	2	3	4	5	Gross weight
Load per axle /t	≤12	≤12	≤12	≤12	≤12	55
Remark	55t for type approval, without hook, counterweight, main winch, and the 5th-8th boom sections					



Hook

Rated loa /t	Number of sheaves	Rope rate	Hook weight/kg
<input type="radio"/> 200	9	19	2440
<input type="radio"/> 125	7	15	1491
<input checked="" type="radio"/> 80	3	7	695
<input type="radio"/> 32	1	3	504
<input checked="" type="radio"/> 12.5	0	1	270

● Standard ○ Optional



Operations

Item	Single rope lifting speed	Rope diameter/length	Max. single line pull
Main winch	0-130 m/min	22 mm/340 m	11t
Slewing speed	0-1.5 r/min		
Full luffing up/down time	65s/115s (0~80°)		
Full extension/retraction time	750s/750s (14.4 m~85.5 m)		
Outrigger jack	Retraction	25s	
	Extension	30s	
Outrigger beam	Retraction	30s	
	Extension	35s	

Crane Introduction

Carrier

Driver's cab

- It is made of SANY independently developed new steel structure with excellent shock absorption and sealing, and designed with outward opening doors, comfortable driver's seat (with head rest) and co-driver's seat equipped with pneumatic suspension, adjustable steering wheel, wide-view rear-view mirror, demister, air conditioner, stereo radio, and complete set of control instruments and meters, which is more comfortable, secure and user-friendly.

Carrier frame

- It is designed and manufactured by SANY in the torsion-proof box-shaped structure welded by fine-grained high-strength steel sheets, which has strong load-bearing capacity.

Chassis engine

- Model: Benz OM460LA.E3A/1 six-cylinder, water-cooled, supercharged intercooler, diesel engine.
- Rated power: 360kW/1800rpm.
- Max. torque: 2200N·m/1300rpm.
- Emission standard: EU Stage III A.
- Fuel reservoir capacity: 500L.

Transmission

- German ZF AMT (with hydraulic retarder to run easily on long-downhill path), with 12 forward gears and 2 reverse gears.

Axle

- It is German Kessler axle in full-axle steering and 4-axle drive (drive axles 1, 2, 4, 5). The axles 1, 2 adopt the hydraulic power steering system with rod system feedback, and the axles 3, 4, 5 adopt the electro-hydraulic control steering, so the assistance for speed control and selectable steering modes can be realized, with easy steering and flexible control.

Suspension system

- All axle suspension devices are height-adjustable hydro-pneumatic suspension devices with hydraulic locking. The suspension can be adjusted up by 140mm and down by 150mm. With suspension, rigid locking, automatic leveling, and lifting modes, it can be applied to various harsh working conditions and roads to ensure the smoothness, lateral stability and comfortable driving of the crane.

Steering

- It consists of servo power steering gear, and dual-circuit system hydraulic steering device, with emergency steering pump.
- There are 6 steering modes: 1. Highway driving mode (default mode); 2. All-wheel steering mode; 3. Crab walk mode; 4. No-yaw steering mode; 5. Independent rear axle steering mode; 6. Rear axle lock steering mode.

Tires

- Standard 11 #385 Techking tires, optional spare tire bracket and #445 Techking.

Drive/Steering

- 10 × 8.

Brake

- Parking brake: It is driven by a pressure accumulator, acting on the second to fifth axles.
- Service brake: All wheels are equipped with air servo brakes, dual-circuit braking system, and disc brakes.
- Assist brake: It includes transmission hydraulic retarder brake, engine brake and exhaust brake, which can reduce the wear of brake system and save the use costs.

Outrigger

- With a longitudinal and transverse pan of 9.5 m × 8.3 m, and fully hydraulic horizontal and vertical support telescopic cylinders, the H-type outriggers functions automatic levelling.

Electrical system

- With modern data bus system, 24V DC power supply, 2 battery packs (180 AH for each), the power supply of chassis can be cut off.
- The carrier adopts CAN bus system and multi-functional centralized display system in low power consumption; as well as LCD screen with adjustable contrast.

Crane Introduction

superstructure



Operator's cab

- 0°-20° tiltable, the operator's cab is made of corrosion-resistant steels, and designed with full-covering softened interior, panoramic sunroof, adjustable seat, etc. to make the operation more user-friendly, comfortable and easy; and equipped with LMI screen to integrate the center console and operation display system and make operation conditions are well monitored from multiple angles.



Boom & telescoping system

- Boom: 8-section boom made of fine-grained high-strength steel, with full extension of 85.5 m, and oval cross-section. Jib: Standard 18 m, and 34 m for optional, mechanically adjusted at 0°, 15°, 30°.
- Telescopic mechanism: With independent hydraulic drive telescopic movement, it is efficient, safe and reliable.



Hoist

- The main winch adopts an electric proportional variable piston motor, which has good inching performance and stability.



Luffing system

- It is designed with passive luffing down, which is more energy-saving. It adopts a single cylinder in front hinged support arrangement to perform the luffing with less effort and improve the force of the boom; and an electric proportional control balance valve is used.



Hydraulics

- It consists of the high-quality main pump, rotary pump, main valve, winch motor, balance and other key hydraulic components to ensure the stability and reliability of the hydraulic system and achieve the superior operating performance through accurate parameter matching; the electric proportional variable piston pump to adjust the pump displacement in real time and realize the high-precision flow control through the change of the electric control handle opening, without energy loss during operation; and the self-developed double-pump confluence/shunt main valve for higher efficiency of single motion, and better diverting control of combined motions.
- With the passive luffing down process with compensation hydraulic system, it has better inching performance and stability. The extension and retraction of boom is realized by a single-cylinder pin telescopic system.
- Under a closed system, the flow and direction are changed by adjusting the angle of the variable pump swash plate to realize superior inching motion and the stable slewing.



Slewing platform

- It is independently designed by SANY in fine-grained high-strength steel, which is more optimized.



Slewing

- It consists of a variable main piston pump for 360° slewing at speed of 0-1.5 r/min; and an electric proportional closed hydraulic circuit and electric proportional pedal to realize emergency braking.



Control system

- The crane is electronically controlled by load moment indicator system; the two multi-directional joysticks can be automatically reset; and the movement of the crane is realized through controlling the hydraulic pump.



Counterweight

- It adopts movable counterweight, which can be moved 500 mm backward, making the 60t counterweight delivering same performance as 68t. 18t counterweight can be loaded with the crane when traveling. The counterweight can be raised and lowered by wireless remote control.



Safety equipment

- LMI: Under analytical mechanics, a load moment calculation system based on the lifting mechanics model is established. Through online empty-load calibration, the rated lifting accuracy can reach $\pm 5\%$ for fully protecting the lifting operation. When overloading, the system will automatically give an alarm to provide safety guarantee for operation. The hydraulic system is equipped with hydraulic balance valve, overflow valve, two-way hydraulic lock and other components to ensure its stability and reliability. The winch is equipped with a protector to prevent the wire rope from over-hoisting down.
- The A2B switch is installed at boom head and jib head to prevent the wire rope from over-winding.
- An anemometer is installed at boom head to detect whether the wind speed at heights exceeds the allowable range.

Operating Range - Telescopic Boom

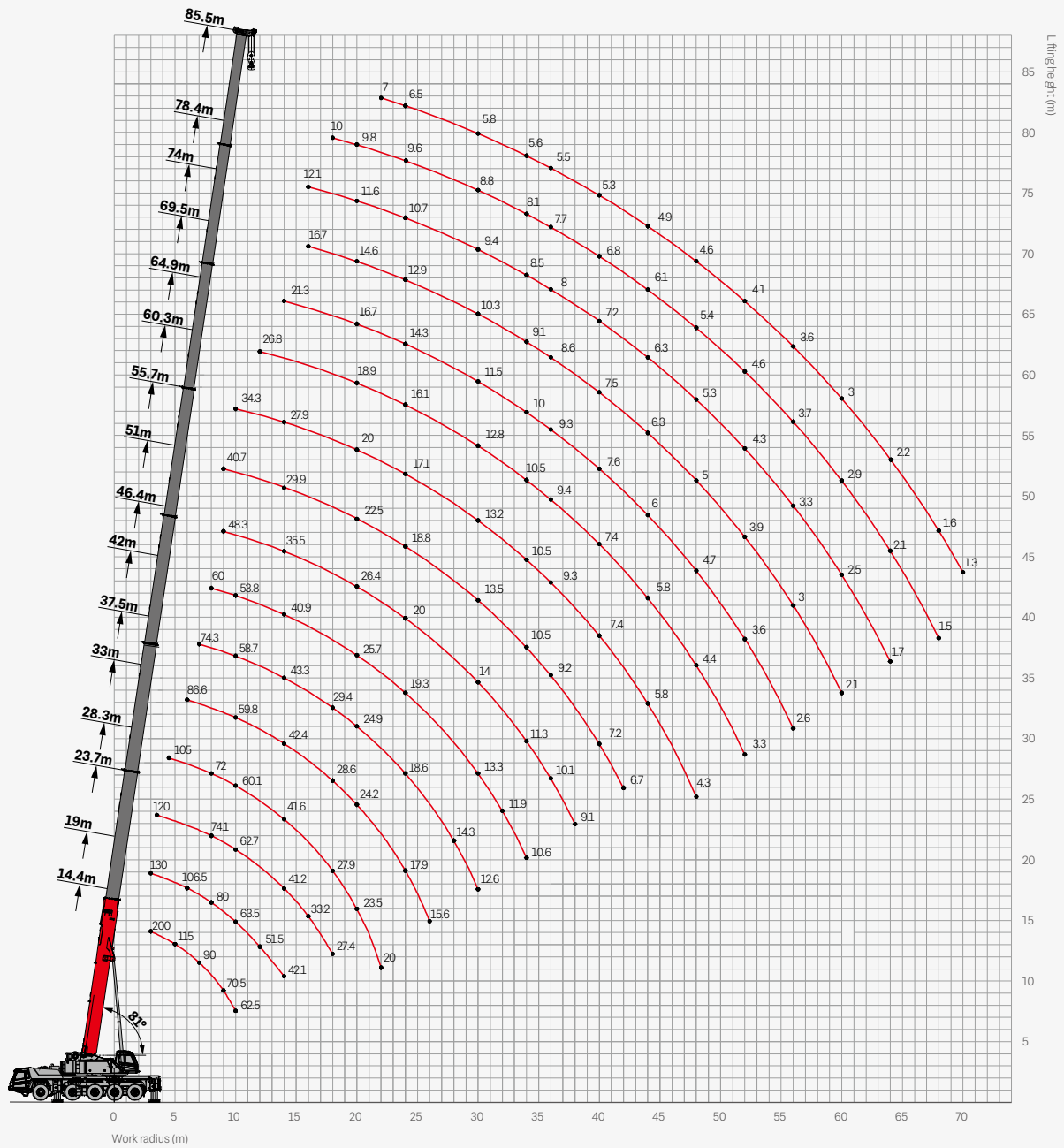

Load Chart-Telescopic Boom



Unit: t

Radius (m)	14.4	19.0	23.7	28.3	33.0	37.5	42.0	46.4	51.0	55.7	60.3	65.0	69.5	74.0	78.4	80.4	83.4	85.5	Radius (m)	
3	200.0*	130.0																		3
3.5	136.0	125.0	120.0																	3.5
4	128.0	120.0	115.3																	4
4.5	121.0	115.0	108.1	105.0																4.5
5	115.0	110.0	101.4	98.4																5
6	103.0	106.5	90.3	87.7	86.6															6
7	90.0	90.0	80.4	78.1	77.6	74.3														7
8	80.0	80.0	74.1	72.0	70.3	68.5	60.0													8
9	70.5	70.5	67.2	66.7	64.8	63.1	57.4	48.3	40.7											9
10	62.5	63.5	62.4	61.5	59.8	58.7	53.8	43.7	37.2	34.3										10
12		51.5	52.7	52.2	51.7	50.7	47.3	39.7	33.4	30.9	26.8									12
14		42.1	41.0	43.0	42.3	43.3	40.9	35.5	29.9	27.9	24.4	21.3								14
16			35.4	35.0	35.8	35.1	36.4	32.5	27.1	25.5	22.3	19.6	16.7	12.1						16
18			29.6	29.2	30.1	30.5	30.5	30.0	24.6	23.2	20.5	18.1	15.6	12.1	10.0	9.5				18
20				25.0	25.6	26.3	25.9	26.5	22.5	20.0	18.9	16.7	14.6	11.6	9.8	9.4	7.8			20
22				22.4	22.1	23.0	22.3	23.1	20.7	18.5	17.4	15.4	13.7	11.1	9.7	9.3	7.6	7.0		22
24					19.6	19.9	20.1	20.2	19.0	17.1	16.1	14.3	12.9	10.7	9.6	8.7	7.3	6.5		24
26					17.3	17.6	18.2	17.6	17.1	15.5	15.0	13.2	12.2	10.2	9.4	8.6	7.2	6.5		26
28						15.6	16.4	15.6	15.1	14.5	13.8	12.3	11.0	9.8	9.1	8.5	7.0	6.1		28
30						14.0	14.7	14.0	13.4	13.2	12.8	11.5	10.3	9.4	8.8	8.3	6.9	5.8		30
32							13.2	12.5	12.0	11.7	11.8	10.7	9.7	8.9	8.5	7.8	6.8	5.7		32
34							12.0	11.3	10.9	10.4	10.5	10.0	9.0	8.5	8.1	7.6	6.7	5.6		34
36							8.0	10.1	9.8	9.5	9.3	9.3	8.6	8.0	7.7	7.2	6.5	5.5		36
38								9.1	8.8	8.7	8.3	8.5	8.0	7.6	7.3	6.9	6.4	5.4		38
40									7.8	7.8	7.4	7.5	7.5	7.2	6.8	6.4	6.2	5.3		40
42									7.0	7.0	6.6	6.9	7.0	6.7	6.4	6.1	5.8	5.2		42
44										6.3	6.1	6.4	6.3	6.3	6.1	5.8	5.5	4.9		44
46										5.5	5.5	5.9	5.9	5.8	5.7	5.5	5.2	4.8		46
48										4.9	4.9	5.4	5.4	5.3	5.4	5.0	4.9	4.6		48
50											4.2	4.9	4.9	4.7	5.1	4.8	4.5	4.4		50
52											3.7	4.4	4.5	4.3	4.6	4.4	4.2	4.1		52
54												3.8	4.1	4.0	4.2	4.1	3.9	3.8		54
56												3.4	3.8	3.6	3.7	3.8	3.7	3.6		56
58													3.3	3.3	3.3	3.4	3.4	3.3		58
60														2.9	3.0	2.9	3.0	3.1	3.0	60
62															2.6	2.4	2.7	2.6	2.6	62
64															2.4	2.1	2.4	2.3	2.2	64
66																1.8	2.0	2.0	1.9	66
68																1.5	1.7	1.7	1.6	68
70																	1.5	1.3	1.3	70
Rope rate	13	12	12	10	8	7	6	5	5	4	3	3	3	3	3	2	2	2		Rope rate

Operating Range - Fixed Jib

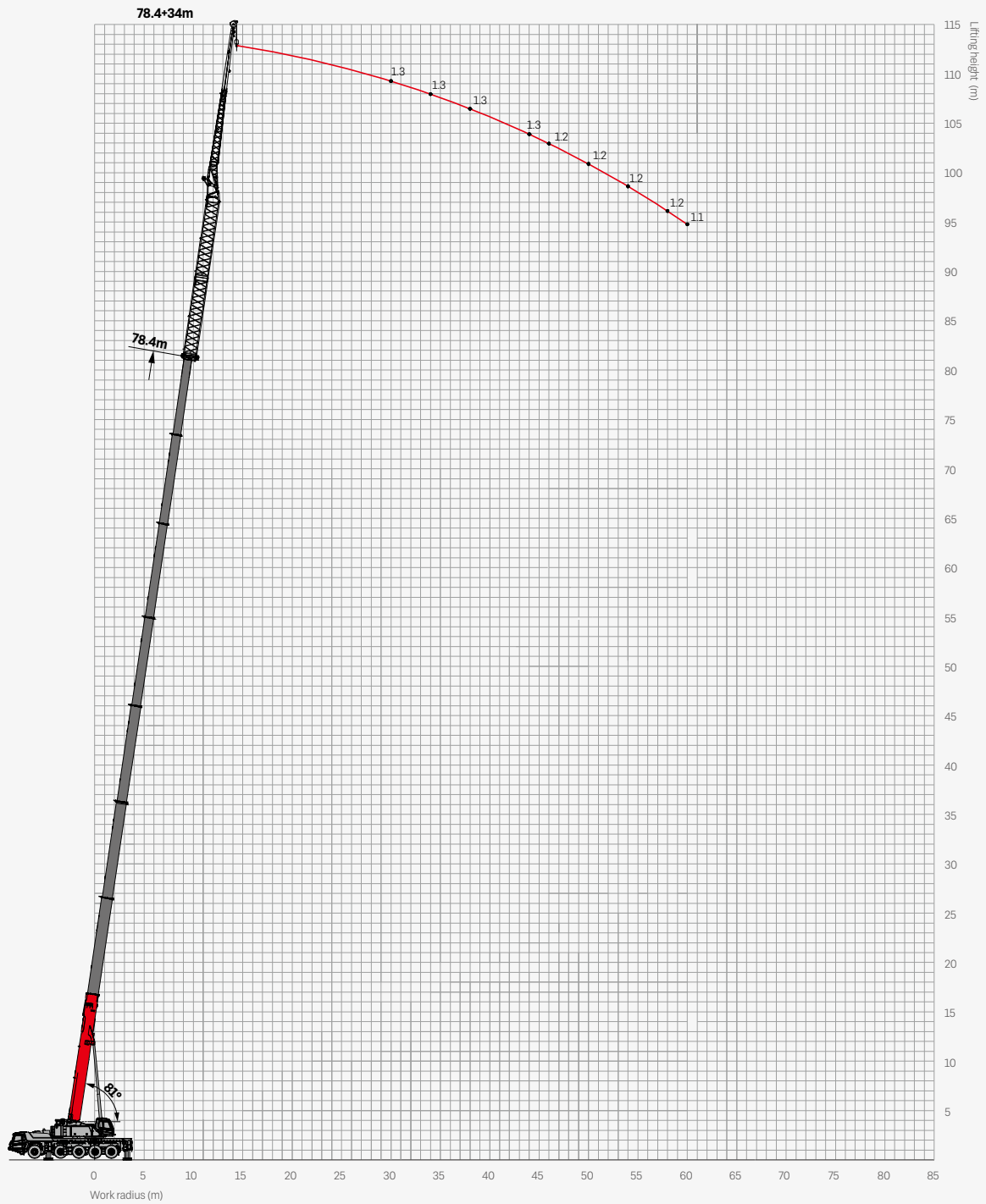

Load Chart - Fixed Jib



Unit: t

Radius (m)	74m+18m (TF)			78.4m+18m (TF)			Radius (m)
	0°	15°	30°	0°	15°	30°	
22	3.3						22
24	3.3	3.5		2.8			24
26	3.3	3.5	2.5	2.8	2.8		26
28	3.3	3.3	2.5	2.8	2.8	2.5	28
30	3.3	3.3	2.5	2.8	2.8	2.5	30
32	3.3	3.2	2.5	2.8	2.8	2.5	32
34	3.3	3.2	2.5	2.8	2.8	2.5	34
36	3.3	3.1	2.5	2.8	2.8	2.5	36
38	3.3	3.1	2.5	2.8	2.8	2.5	38
40	3.3	3.0	2.5	2.8	2.8	2.4	40
42	3.3	3.0	2.5	2.8	2.6	2.4	42
44	3.2	2.8	2.4	2.8	2.6	2.4	44
46	3.1	2.7	2.3	2.8	2.5	2.3	46
48	3.0	2.6	2.2	2.8	2.5	2.3	48
50	3.0	2.5	2.1	2.6	2.4	2.3	50
52	2.9	2.4	2.0	2.6	2.4	2.2	52
54	2.9	2.3	1.9	2.5	2.3	2.1	54
56	2.8	2.2	1.9	2.5	2.2	2.0	56
58	2.5	2.1	1.8	2.4	2.2	2.0	58
60	2.1	2.1	1.8	2.3	2.2	1.9	60
62	1.7	2.1	1.8	2.0	2.1	1.9	62
64	1.4	1.7	1.7	1.6	2.0	1.8	64
66	1.0	1.5	1.7	1.3	1.7	1.8	66
68	0.8	1.1	1.3	1.0	1.3	1.6	68
70	0.5	0.8	1.0	0.7	1.1	1.3	70
72		0.5	0.7	0.5	0.7	0.9	72
74						0.7	74
Telescoping status	2222221			2222222			Telescoping status
Rope rate	1	1	1	1	1	1	Rope rate

Load Chart - Fixed Jib



Unit: t

Radius (m)	74m+34m (TF)		78.4m+34m (TF)		Radius (m)
	0°		0°		
30	1.7				30
32	1.7		1.3		32
34	1.7		1.3		34
36	1.6		1.3		36
38	1.6		1.3		38
40	1.6		1.3		40
42	1.5		1.3		42
44	1.5		1.3		44
46	1.5		1.2		46
48	1.4		1.2		48
50	1.4		1.2		50
52	1.4		1.2		52
54	1.3		1.2		54
56	1.3		1.2		56
58	1.3		1.2		58
60	1.2		1.1		60
62	1.2				62
64	0.9				64
Telescoping status	2222221		2222222		Telescoping status
Rope rate	1		1		Rope rate



SANY GROUP CRANE BU

SANY Mobile Crane Industrial Park, No.168 Jinzhou Avenue, Jinzhou Development Zone, Changsha City,
Hunan Province, P.R. China Zip 410600
Consulting sanycrane@sanygroup.com (Crane BU) / crd@sany.com.cn (IHQ)
After-sales Service 0086-400 6098 318

Reminder:

Any change in the technical parameters and configuration due to product modification or upgrade may occur without prior notice. The machine in the picture may include additional equipment. This brochure is for reference only, and goods in kind shall prevail.

Copyright at SANY. No part of this brochure may be copied or used for any purpose without written approval from SANY.

© Edited in April 2022

